

FORCE HAMMERS

RS3500 SERIES

HYDRAULIC BREAKER

Technical Specification

TECHNICAL SPECIFICATION RS3500

*Disclaimer: Please contact a Force representative for clarification on specifications and options. Force reserves the right to make changes to the information on this data sheet without prior notification to users.

Item/Model	Unit	RS3500
Top Type Weight	kg	2850
Box Type Weight	kg	3000
Length	mm	3100
Pressure	bar	240-260
Flow	lpm	180-240
Rate	bmp	250-400
Hose	inch	1¼
Chisel	mm	155
Suit	ton	28-40



RS3500 Main Body Ass'y

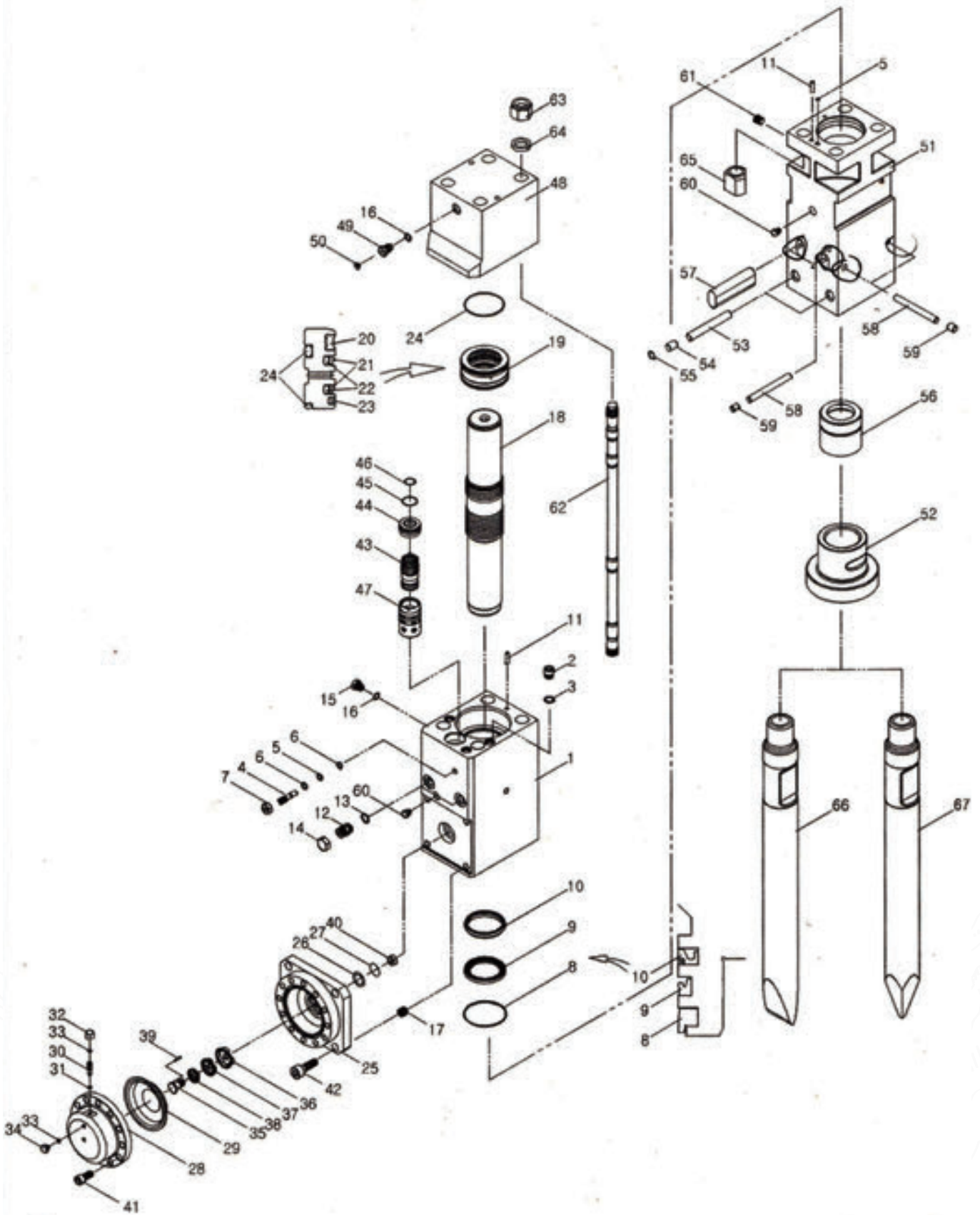

FORCE HAMMERS

NO	PART NO	PART NAME	Q'YT
		CYLINDER ASS'Y	
1	1200M1102	CYLINDER	1
2	1200M1135	SOCKET PLUG	3
3	OR055	O-RING	3
4	1200M1124	VALVE ADJUSTER	1
5	OR044	O-RING	1
6	BR004	BACK UP RING	2
7	HN2215	HEX NUT	1
8	DS015	DUST SEAL	1
9	UP016	U-PACKING	1
10	BS017	BUFFER SEAL	1
11	400M1118	KNOCK PIN	2
12	1200M1125	MALE ADAPTER	2
13	OR057	O-RING	2
14	1200M1125-1	UNION CAP	2
15	100M1127	AIR CHECK VALVE	1
16	OR046	O-RING	2
17	HC243015	HELI SERT COIL	4
18	1200M1104	PISTON	1
		SEAL RETAINER ASS'Y	
19	1200M1108	SEAL RETAINER	1
20	GS015	GAS SEAL	1
21	SS014	STEP SEAL	2
22	OR082	O-RING	2
23	BR002	BUFFER AING	1
24	OR036	O-RING	3
		ACCUMULATOR ASS'Y	
25	1200M1109	ACCUMULATOR BODY	1
26	OR026	O-RING	1
27	BR022	BACK UP RING	1
28	1200M1110	ACCUMULATOR COVER	1
29	1200M1128-1	DIAPHRAGM	1
30	280F1128-2	ACC CHARGING VALVE	1
31	OR001	O-RING	1
32	280F1128-3	ACC CHARGING VALVE CAP	1
33	OR014	O-RING	2
34	180F1128-4	CHARGING PLUG	1
35	1200M1128-8	HOLDER PIN	1
36	1200M1128-5	HOLDER-A	1
37	1200M1128-6	HOLDER-B	1
38	1200M1128-7	HOLDER-C	1
39	1200M1128-9	CENTER PIN	1
40	180F1128-10	HOLDER NUT	1
41	WB162045	SOCKET BOLT	12
42	WB243065	SOCKET BOLT	4
43	1200M1106	VALVE	1
44	1200M1107	VALVE PLUG	1
45	OR027	O-RING	1
46	OR022	O-RING	1
47	1200M1105	VALVE SLEEVE	1

NO	PART NO	PART NAME	Q'YT
		BACK HEAD ASS'Y	
48	1200M1103	BACK HEAD	1
49	100M1127	CHARGING VALVE	1
50	100M1127-1	CHARGING VALVE PLUG	1
		FRONT HEAD ASS'Y	
51	1200M1101	FRONT HEAD	1
52	1200M1112	LOWER BUSH	1
	1200M1112-B	LOWER BUSH (BOX TYPE)	1
53	1200M1120	STOP PIN-L	2
54	RP004	RUBBER PLUG-L	2
55	SP026	SNAP RING	2
56	1200M1111	UPPER BUSH	1
57	1200M1119	ROD PIN	2
58	1200M1121	STOP PIN-UR	3
59	RP001	RUBBER PLUG-UR	3
60	100M1139	GREASE NIPPLE	2
61	HHP1214	HOLLOW HEX PLUG	1
62	1200M1114	THROUGH BOLT	4
63	1200M1115	HEX NUT	4
64	1200M1117	WASHER	4
65	1200M1116	ROUND NUT	4
66	1200M1113	WEDGE CHISEL	1
67	1200M1113-1	MOIL POINT TOOL	1

FORCE HAMMERS

RS3500 Box Bracket

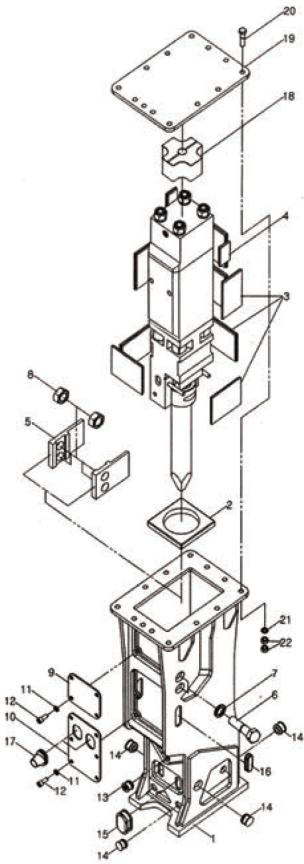

NO	PART NO	PART NAME	Q'YT	MEMO
		FRAME ASSY	1Set	
1	1200M2101	FRAME	1	
2	1200M2105	LOWER DAMPER	1	
3	180F2106	SIDE DAMPER-A	8	
4	100M2106-4	SIDE DAMPER-B	2	
5	1200M2103	GUIDE PLATE	2	
6	HB3940110	SIDE HEX BOLT	4	
7	SW40	SPRING WASHER	4	
8	HN3940	HEX NUT	4	
9	1200M2109	COVER PLATE-A	1	
10	1200M2109-1	COVER PLATE-B	1	
11	SW16	SPRING WASHER	10	
12	WB162030	WRENCH BOLT	10	
13	PL009	GREASE PLUG	1	
14	PL008	STOP PIN PLUG	10	
15	PL014	ROD PIN PLUG	2	
16	PL018	ADAPTER PLUG	2	
17	PL022	IN/OUT PLUG	2	
18	1200M2104	UPPER DAMPER	1	
19	1200M2109	UPPER PLATE	1	
20	HB3640140	HEX BOLT	12	
21	SW36	SPRING WASHER	12	
22	HN3640	HEX NUT	24	

RS3500 Top Bracket

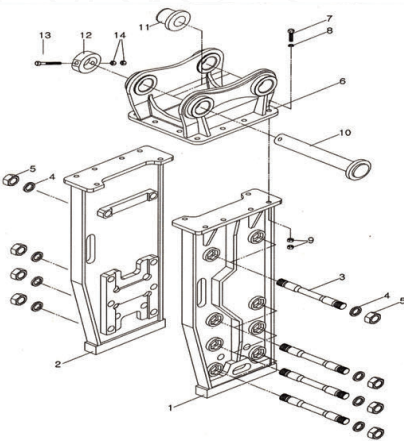

NO	PART NO	PART NAME	Q'YT
		FRAME ASSY	
1	1200M3101	FRAME-R	1
2	1200M3101-1	FRAME-L	1
3	1200M3103	SIDE BOLT	8
4	1200M3105	WASHER	8
5	1200M3104	SIDE NUT	16
6	1200M3102	MOUNT CAP	1
7	HB3640140	M/C HEX BOLT	12

NO	PART NO	PART NAME	Q'YT
8	SW36	M/C SPRING WASHER	12
9	HN3640	M/C HEX NUT	24
10	1200M3106	PIN	2
11	1200M3106-1	T-BUSH	4
12	1200M3106-2	STOP BAR	2
13	HB1620200	PIN HEX BOLT	2
14	HN1620	PIN HEX NUT	4

FORCE HAMMERS PTY LTD.

📍 Address 64 Buckingham Drive, WANGARA, ABN 85 676555990
Mail PO Box 988, Joondalup DC, Perth Western Australia 6065

☎ 1300 820 603