

FORCE HAMMERS

RS100 SERIES

HYDRAULIC BREAKER

Technical Specification

TECHNICAL SPECIFICATION RS100

*Disclaimer: Please contact a Force representative for clarification on specifications and options. Force reserves the right to make changes to the information on this data sheet without prior notification to users.

Item/Model	Unit	RS100
Top Type Weight	kg	85
Box Type Weight	kg	100
Length	mm	1000
Pressure	bar	100-150
Flow	lpm	15-25
Rate	bmp	900-1400
Hose	inch	1/2
Chisel	mm	40
Suit	ton	0.8-2.0



FORCE HAMMERS

RS100 Main Body Ass'y

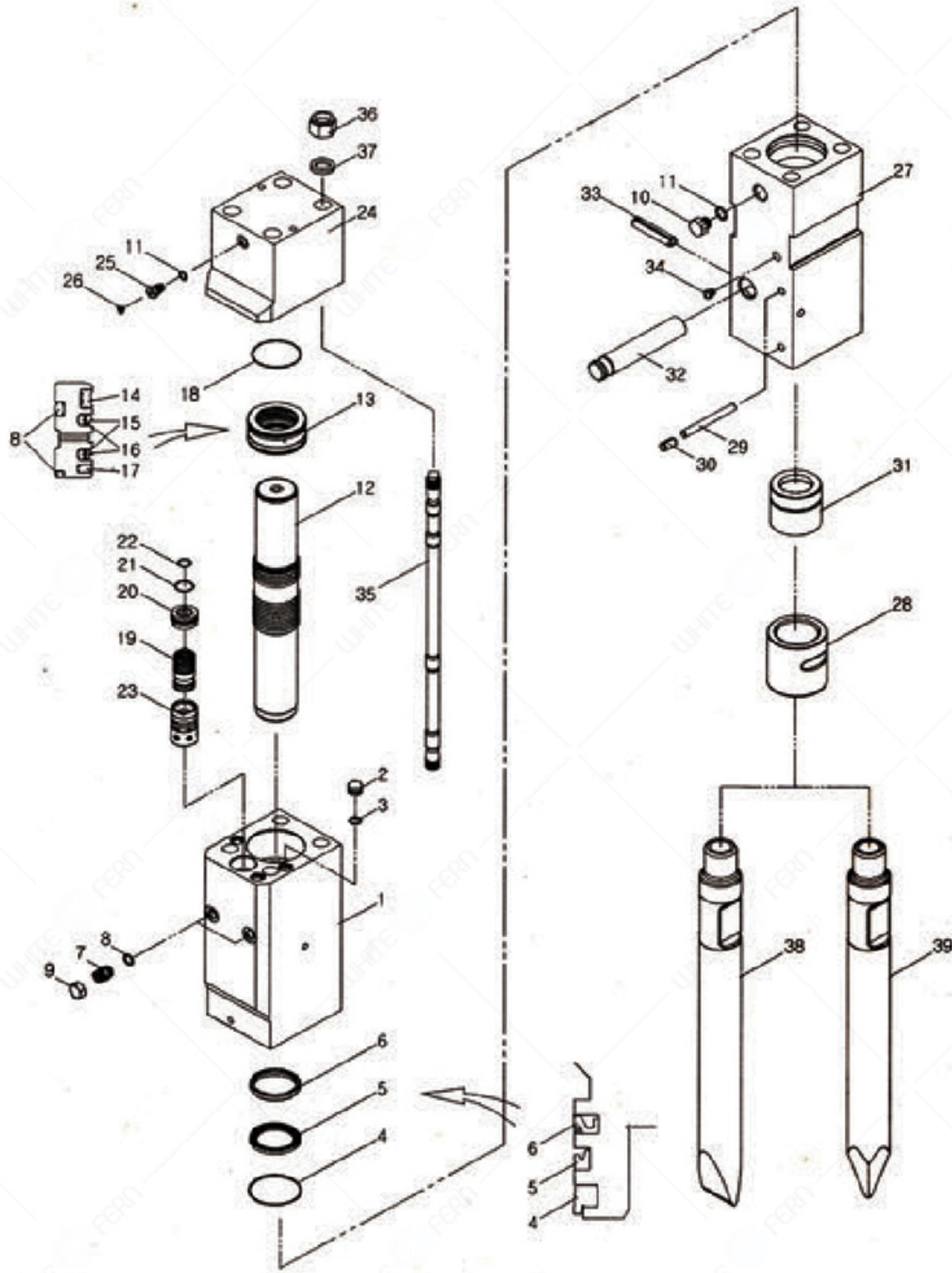

NO	PART NO	PART NAME	Q'YT	MEMO
		CYLINDER ASS'Y		
1	100M1102	CYLINDER	1	
2	100M1137	TEFLON PLUG	3	
3	OR008	O-RING	3	
4	DS002	DUST SEAL	1	
5	UP002	U-PACKING	1	
6	BS004	BUFFER SEAL	1	
7	100M1125	MALE ADAPTER	2	
8	OR010	O-RING	2	
9	100M1125-1	UNION CAP	2	
10	100M1127	AIR CHECK VALVE	1	
11	OR009	O-RING	2	
12	100M1104	PISTON	1	
		SEAL RETAINER ASS'Y	1	
13	100M1108	SEAL RETAINER	1	
14	GS002	GAS SEAL	1	
15	SS002	STEP SEAL	2	
16	OR070	O-RING	2	
17	BS003	BUFFER SEAL	1	
18	OR014	O-RING	3	
19	100M1106	VALVE	1	
20	100M1107	VALVE PLUG	1	
21	OR011	O-RING	1	
22	OR013	O-RING	1	
23	100M1105	VALVE SLEEVE	1	
		BACK HEAD ASS'Y		
24	100M1103	BACK HEAD	1	
25	100M1127	CHARGING VALVE	1	
26	100M1127-1	CHARGING VALVE PLUG	1	
		FRONT HEAD ASS'Y		
27	100M1101	FRONT HEAD	1	
28	100M1112	LOWER BUSH	1	
29	100M1120	STOP PIN	2	
30	SP1335	SPRING PIN	2	
31	100M1111	UPPER BUSH	1	
32	100M1119	ROD PIN	1	
33	SP1060	SPRING PIN	1	
34	100M1139	GREASE NIPPLE	1	
35	100M1114	THROUGH BOLT	4	
36	100M1115	HEX NUT	4	
37	100M1117	WASHER	4	
38	100M1113	WEDGE CHISEL	1	
39	100M1113-1	MOIL POINT TOOL	1	

RS100 Top Bracket

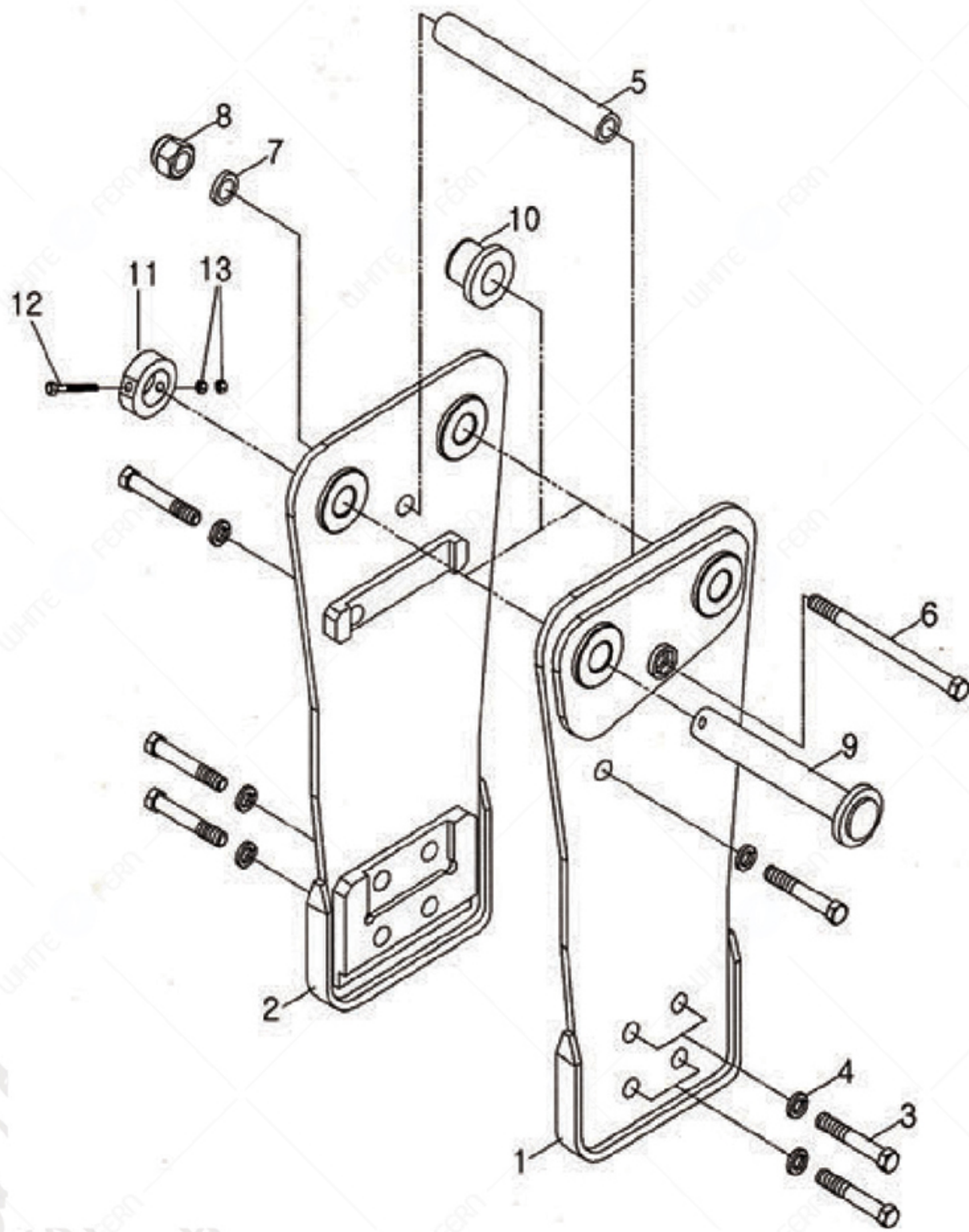

NO	PART NO	PART NAME	Q'YT
		FRAME ASSY	
1	100M3101	FRAME-R	1
2	100M3101-1	FRAME-L	1
3	HB181570	HEX BOLT	10
4	SW18	SPRING WASHER	10
5	100M3107	SPACER	1
6	HB1815190	SPACER HEX BOLT	1
7	SW18	SPACER SPRING WASHER	1
8	CN1815	SPACER CAP NUT	1
9	100M3106	PIN	2
10	100M3106-1	T-BUSH	4
11	100M3106-2	STOP BAR	2
12	HB1217585	PIN HEX BOLT	2
13	HN12175	PIN HEX NUT	4

FORCE HAMMERS PTY LTD.

📍 Address 64 Buckingham Drive, WANGARA, ABN 85 676555990
Mail PO Box 988, Joondalup DC, Perth Western Australia 6065

☎ 1300 820 603